

UltraClean NovoDoser® 2000DSC



A new generation ultra-clean liquid nitrogen doser with frost-free nozzle, corrosion resistant 316L material grade construction, hygienic wash-down design in compliance to stringent ultra clean bottling line requirement

Specifications

- Discrete dosing up to 2000 CPM
- Controller with Siemen S7-1200 PLC platform
- NEMA 4X IP65 stainless steel enclosure
- HMI comes with TFT color touch screen
- Minimum dose duration 5mS
- Accurate dose weight +/-1%
- No container No dose function
- Smart-maintenance to allow user plan the maintenance schedule
- Direct LN2 feed pressure up to 100 psi (6.8 Bar)
- ModBus user interface
- Alarm log to assist system trouble shooting and performance monitoring
- Recipe storage 10 recipes or more
- 316L material construction higher corrosion resistance
- HS Hygienic Dosing Head wash-down design, IP65 rated
- Multi-lingual HMI: English, Spanish, Chinese, etc

Ergonomic Features and Benefits

- **Frost-free Nozzle** – Self-generating GN2 for dosing head blanketing
- **Lowest LN2 Consumption** – Discrete dosing, for speed up to 2000* containers per minute
- **Lowest LN2 Losses** – Proprietary vacuum insulation with lowest heat leak 0.1 LPH
- **Minimized Product Splash** – Lowest dose pressure in its class, 0.3 psi
- **Sub-cooled LN2** – Ensuring constant LN2 density for accurate dosing
- **Corrosion Resistant** – 316L material grade of construction for doser body
- **Ease of Maintenance** – Achievable by system smart maintenance and remote monitoring
- **Highest Hygiene Design** – All external surface has rounded corners and sloped design for easy wash-down
- **Lowest Maintenance** – Ultra long life cycle dosing valve > 60 million; and IP 65 rated sensors & electrical cables
- **Ease of Installation** – Compact size for easy installation in limited space
- **Applications Flexibility** – Compatible with soft-dose and micro-dose technology for hot fill, powder, and granular applications
- **5 Years Vacuum Warranty** – Lowest cost of ownership

UltraClean NovoDoser® 2000DSC

Dimensions

Material	Stainless Steel Series 316L
Head Pressure	0.3psi
Nozzle Blanketing	Self Generate N2
Steady State Consumption	< 0.03 gal (0.1 liter) / hour
Body Dimension	Customized to filler
Dosing Head Dimension	EA Head 9.5"H x 2"W (241 x 50mm)
Dosing Head Arm Reach	Customized to filler
Weight	30lbs (14kg)
Utilities	Liquid Nitrogen : ≤ 100 psi Gaseous N2 : 60 - 100 psi Electrical : 110-220VAC

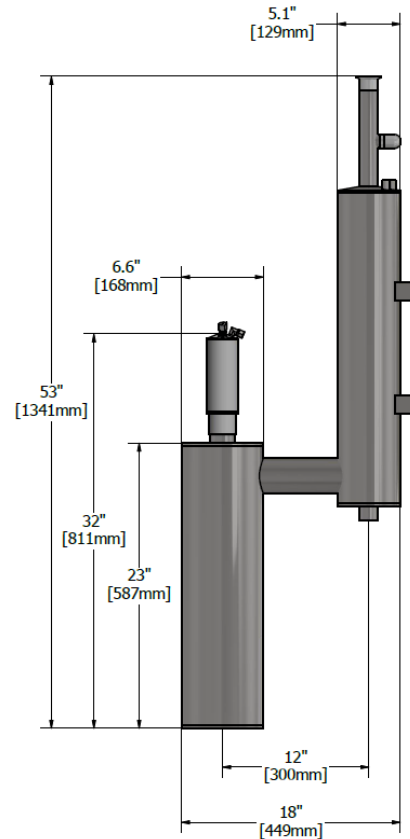

2000DSC Controller Specifications

PLC Platform	Siemens S7-1200
HMI (LCD touch screen)	7.0" Color
Dose Duration, 1ms int.	5 to 1000 ms
Dose Volume, mg/dose	5 to 1400
Dose Accuracy	± 1%
Max. Discrete Dosing	2000 CPM
Fixed Delay	✓
Speed Compensation	✓
Dose Compensation	✓
Encoder Compatible	✓
Thermomatic Sanitization	✓
Nozzle Auto Defrost	Automatic
Nozzle Pre-Cooling	Automatic
User's Filler Signal Interface	Optional
Modbus RTU User Interface	✓
Mobile Remote Monitoring (Wi-Fi / Lan)	✓
Smart Maintenance	✓
Overall Equipment Effectiveness	✓
Recipe Storage	12
HS Hygienic Dosing Head	✓
Certifications	CE, IP66

